

Diagram technique for models with internal Lie-group dynamics

This article has been downloaded from IOPscience. Please scroll down to see the full text article.

2007 J. Phys. A: Math. Theor. 40 11791

(<http://iopscience.iop.org/1751-8121/40/39/007>)

View [the table of contents for this issue](#), or go to the [journal homepage](#) for more

Download details:

IP Address: 171.66.16.144

The article was downloaded on 03/06/2010 at 06:15

Please note that [terms and conditions apply](#).

Diagram technique for models with internal Lie-group dynamics

L V Lutsev

Research Institute 'Ferrite-Domen', Chernigovskaya 8, Saint Petersburg 196084, Russia

E-mail: lutsev@domen.ru

Received 3 July 2007

Published 11 September 2007

Online at stacks.iop.org/JPhysA/40/11791

Abstract

Nanosystems and strongly correlated systems can possess a more complicated internal Lie-group dynamics in comparison with the Lie-group dynamics of Bose and Fermi systems described by the Heisenberg algebra and superalgebra, respectively. In order to investigate properties of such quantum systems, we represent operators of quantum systems by differential operators over a commutative algebra of regular functionals and develop a new diagram technique on the basis of the expansion of the generating functional for the temperature Green functions. The differential representation makes it possible to generalize functional equations and the diagram technique for the case of quantum systems on topologically nontrivial manifolds by the substitution of the generating functional on a sheaf of function rings on a nontrivial manifold for the generating functional of a constant sheaf of functions. Nontrivial cohomologies of the manifold, on which the quantum system is acted, lead to the existence of additional excitations. We consider the self-consistent-field approximation and the approximation of effective Green functions and interactions. Poles of the matrix of effective interactions and Green functions determine quasi-particle excitations of the quantum system. For special cases of models the diagram expansion is simplified. In particular, if the internal dynamics is determined by the Heisenberg algebra (superalgebra), the diagram expansion reduces to Feynman's diagrams for Bose (Fermi) quantum systems. We consider the reduction of the developed diagram technique and excitations for the case of the spin system with an uniaxial anisotropy.

PACS numbers: 03.65.Db, 05.30.-d, 11.10.Wx

1. Introduction

In order to study strongly correlated systems and nanosystems, we ought to use mathematical models and methods, which can adequately describe processes with strong electron interactions

and processes performing on a nanosized scale. In nanosystems these processes can be characterized by strong local interactions in the interior of nano-objects and by correlation effects between different phases and substructures [1, 2]. One of the effective theoretical tools for investigation of strongly interacting electronic systems is the diagram technique based on expansions of Green functions. The diagram expansion is the powerful method to obtain various information of interacting particle systems in the quantum field theory and in the statistical physics. Using the diagram technique, one can find spectra of quasi-particle excitations, calculate transition probabilities, determine temperature dependencies of thermodynamic potentials and obtain relaxation parameters of excitations.

On the particle level, quantum systems are described by operators, which belong to Lie algebras or to Lie superalgebras. Operators can be associated with generators of continuous transformations related to Lie groups, which determine internal dynamics of quantum systems. For Bose and Fermi systems, the internal dynamics is simple and is given by the Heisenberg–Weyl group and the Heisenberg–Weyl supergroup, respectively. The corresponding Lie algebras (the Heisenberg algebra and the Heisenberg superalgebra) are formed by creation and annihilation operators. The diagram expansion is given by well-known Feynman’s diagrams [3, 4].

Models of antiferromagnetism and superconductivity, the Heisenberg and Hubbard models, are examples of models with more complicated internal dynamics [5–15]. In the Heisenberg model, the internal dynamics of a spin system is described by the Lie group $Spin(3)$. The Lie algebra $so(3)$ is associated with this group and is spanned on spin operators. In order to develop the diagram technique, Wick’s theorem for spin operators is used [7–9]. For the case of the Hubbard model, the internal dynamics is determined by the supergroup with the Lie superalgebra $sl(2, 2)$ [10, 11]. The diagram expansion is constructed by the two-step procedure based on Wick’s theorem [12–15]. The model describing antiferromagnetic and superconducting systems presented in [6] is based on the internal group $SO(5)$.

At present, we can observe the tendency to study models with complicated internal Lie-group dynamics. Transformation from the particle level of strongly interacting electronic systems to the cluster level (quantum cluster approaches [16, 17]) results in consideration of more complicated Lie groups. Cluster approaches give us opportunity to describe the internal local dynamics of a cluster and to find short-ranged correlations with higher precision. Moreover, for a given strongly correlated system we can use several operator languages with different corresponding Lie algebras [18]. The determination of an isomorphism between different languages unveils unravel symmetries, which are hidden in one representation but become manifest in another.

From the above-mentioned one can conclude that for studying nanosystems and strongly correlated systems the generalization of the diagram technique is needed. The generalized diagram expansion should satisfy the following conditions. (1) It must describe models with arbitrary internal Lie-group dynamics. (2) The developing diagram technique must take into account topology of quantum systems. In this study, in order to develop the generalized diagram expansion, we represent operators of quantum systems by differential operators over a commutative algebra of regular functionals. Taking into account this differential representation, we construct a new diagram technique based on the expansion of the generating functional for the temperature Green functions. The generating functional is determined by differential functional equations. These equations are derived in section 2 from evolution operator equations by substitution for Lie-algebra operators of differential operators over a commutative algebra of functionals. Solutions of the differential functional equations are found in the form of series (or in the form of the diagram expansion) in section 3. This method of the construction of the diagram expansion is more general than the methods based on

the Wick theorem and on the expansion of functional integrals [7–9, 12–15]. The developing diagram construction based on differential functional equations gives us opportunity to describe quantum systems on topologically nontrivial differential manifolds and to investigate the differential functional equations by the secondary differential calculus and by cohomology methods [19–22]. For this realization, we generalize the differential functional equations and the diagram expansion in section 4 for the case of functionals determined on a sheaf of function rings on a topologically nontrivial manifold. In this way, cohomology methods are important in the equation investigation. First, solutions of the differential functional equations exist if and only if Spencer’s cohomologies are trivial. This condition can impose constraint relations on the form of interactions between particles. Singularities of many-valued solutions are determined by the acyclicity of Spencer’s δ -complex. Second, in the general case, de Rham’s cohomologies of a topologically nontrivial manifold are nontrivial. Nontrivial de Rham’s cohomologies lead to the existence of additional quantum excitations.

The advantage of the developing diagram technique is the opportunity to construct effective cluster approximations for models with strong local interactions. It can be realizable, if we substitute composite (cluster) operators for single-particle operators in the Hamiltonian describing a model. Composite operators belong to the universal enveloping algebra, whose basis is determined by single-particle operators. This operator substitution leads to the substitution of Lie algebras. The original Lie algebra $\mathcal{L}^{(0)}$ describing the internal dynamics of the quantum system is replaced by the Lie algebra $\mathcal{L}^{(1)}$, which includes $\mathcal{L}^{(0)}$ as the subalgebra: $\mathcal{L}^{(0)} \subset \mathcal{L}^{(1)}$.

Special cases of diagram expansions are considered in section 5. For the case of the Heisenberg algebra (superalgebra), the diagram expansion reduces to Feynman’s diagrams for Bose (Fermi) quantum systems. The simplification of the diagram technique occurs for models with semi-simple Lie algebras and with simple contragredient Lie superalgebras. In section 6, we introduce the self-consistent-field approximation and determine the matrix of effective Green functions and interactions (the \mathcal{P} -matrix) by summation of series of bare propagators and interaction lines. Quasi-particle excitations of the quantum system are determined by poles of the \mathcal{P} -matrix. As the particular case, in section 7 we consider the diagram technique and excitations in the spin system model with an uniaxial anisotropy.

2. Functional equations

Let us consider a model with an internal Lie-group dynamics on a crystal lattice with the Hamiltonian

$$\mathcal{H} = \mathcal{H}_0 + \mathcal{H}', \quad (1)$$

where

$$\mathcal{H}_0 = \mathcal{H}_b + \mathcal{H}_V = \sum_{\vec{1}, j} b_j(\vec{1}) \sigma_j(\vec{1}) + \sum_{\substack{\vec{1}, \vec{1}' \\ i, j}} V_{ij}(\vec{1} - \vec{1}') \sigma_i(\vec{1}) \sigma_j(\vec{1}'), \quad (2)$$

$\vec{1} \equiv \vec{r}_{n_1}$, $\vec{1}' \equiv \vec{r}'_{n_1}$ is the abridge notation of crystal lattice sites, $b_j(\vec{1})$ are the external fields and $V_{ij}(\vec{1} - \vec{1}')$ is the interaction. Operators $\sigma_j(\vec{1})$ can characterize different properties of quantum systems and can be the operators of energies on quantum levels, spin operators, operators of the number of particles, electrical dipole operators, etc. The fields $b_j(\vec{1})$, corresponding to $\sigma_j(\vec{1})$, are energies, magnetic fields, chemical potentials, electrical fields, respectively. Operators $\sigma_j(\vec{1})$ satisfy the commutation relation

$$[\sigma_i(\vec{1}), \sigma_j(\vec{1}')] = \sum_m C_{ij}^m \sigma_m(\vec{1}) \delta_{\vec{1}\vec{1}'}, \quad (3)$$

and form the Lie algebra (superalgebra) \mathcal{L} on the given site $\vec{1}$. The algebra (superalgebra) \mathcal{L} determines the internal Lie-group dynamics of the quantum system. If \mathcal{L} is the Lie superalgebra, the bracket

$$[\sigma_i(\vec{1}), \sigma_j(\vec{1}')] = \sigma_i(\vec{1})\sigma_j(\vec{1}') - \kappa_{ij}\sigma_j(\vec{1}')\sigma_i(\vec{1}),$$

where $\kappa_{ij} = (-1)^{\deg \sigma_i \deg \sigma_j}$, depends on parity degrees $\deg \sigma_i(\vec{1}), \deg \sigma_j(\vec{1}')$ of operators $\sigma_i(\vec{1}), \sigma_j(\vec{1}')$, respectively. Values of the degree, $\deg \sigma_k = 0$ and $\deg \sigma_k = 1$, denote that the operator σ_k is the simple variable or the Grassmanian variable, respectively. We suppose that operators $\sigma_k(\vec{1})$ and corresponding fields $b_k(\vec{1})$ in relation (2) have equal parity degrees, $\deg \sigma_k(\vec{1}) = \deg b_k(\vec{1})$, and Hamiltonians $\mathcal{H}_b, \mathcal{H}_V, \mathcal{H}'$ are of simple variables, $\deg \mathcal{H}_b = \deg \mathcal{H}_V = \deg \mathcal{H}' = 0$. We also assume that the quantum system described by the Hamiltonian \mathcal{H}_0 is in the thermodynamic equilibrium and is characterized by the temperature T . In the thermodynamic equilibrium the set of r commuting operators $\{\sigma_j^{(c)}(\vec{1})\}$, which is the subset of operators $\{\sigma_j(\vec{1})\}$, gives the set of observable variables. The set $\{\sigma_j^{(c)}(\vec{1})\}$ determines the set of statistical average values $\langle\langle \sigma_j(\vec{1}) \rangle\rangle_0$ differed from zero, where $\langle\langle \dots \rangle\rangle_0$ denotes averaging calculated with the Hamiltonian \mathcal{H}_0 . In the thermodynamic equilibrium the external fields $b_j(\vec{1})$, corresponding to operators $\{\sigma_j^{(c)}(\vec{1})\}$, can be of arbitrary nonzero values.

It is a need to note that the bilinear form of the Hamiltonian \mathcal{H}_0 with the bilinear interaction in the definition (2) is general. If the interaction Hamiltonian is given by

$$\mathcal{H}_V = \sum_{\substack{\vec{1}, \vec{1}' \\ i_1, \dots, i_n, j_1, \dots, j_k}} V_{i_1 \dots i_n j_1 \dots j_k}(\vec{1} - \vec{1}') a_{i_1}(\vec{1}) \dots a_{i_n}(\vec{1}) a_{j_1}(\vec{1}') \dots a_{j_k}(\vec{1}'),$$

then the transformation to the bilinear form is realized by the substitution of operators $\sigma_i(\vec{1}) = a_{i_1}(\vec{1}) \dots a_{i_n}(\vec{1}), \sigma_j(\vec{1}') = a_{j_1}(\vec{1}') \dots a_{j_k}(\vec{1}')$ for operators a_i . The set of operators $\{\sigma_i(\vec{1})\}$ generates the Lie algebra $\mathcal{L}^{(1)}$ differed from the original Lie algebra $\mathcal{L}^{(0)}$, whose basis is formed by operators a_i . The special case of this transformation to the bilinear form is the transformation from the model of strongly interacting Fermi electronic systems to the Hubbard model [10–15].

The Hamiltonian

$$\mathcal{H}' = \sum_{\vec{1}, j} p_j(\vec{1}) \sigma_j(\vec{1}) \quad (4)$$

describes the interaction with the auxiliary fields $p_j(\vec{1})$. We assume that in the Hamiltonian $\mathcal{H}' \deg \sigma_j(\vec{1}) = \deg p_j(\vec{1})$. In the case of models with internal dynamic Lie algebras, the set of fields $p = \{p_j(\vec{1})\}$ forms the commutative ring of functions. For models with Lie superalgebras fields p form the anticommutative ring.

Using the Hamiltonian (1), we can determine the generating functional

$$Z[p] = \text{Sp} \exp[-\beta \mathcal{H}(p)], \quad (5)$$

where $\beta = 1/kT$, k is the Boltzmann constant. In order to analyze temperature characteristics of the quantum system, we ought to derive differential equations for the generating functional. These equations can be found from the evolution operator equations

$$\frac{\partial \hat{\sigma}_j(\vec{1}, \tau)}{\partial \tau} = [\mathcal{H}, \hat{\sigma}_j(\vec{1}, \tau)] \quad (\tau \in [0, \beta]) \quad (6)$$

by averaging with the operator $\exp[-\beta \mathcal{H}(p)]$, where $\hat{\sigma}_j(\vec{1}, \tau) = \exp(\tau \mathcal{H}) \sigma_j(\vec{1}) \exp(-\tau \mathcal{H})$ are the operators in the Euclidean–Heisenberg representation. Without loss of generality, we include the constant β into the definitions of the external fields b_j , the interaction V_{ij}

and the auxiliary fields p_j in relations (2) and (4), respectively, and transform the range of values of τ in equation (6). In other words, we perform the scale transformation: $-\beta b_j \rightarrow b_j, -\beta V_{ij} \rightarrow V_{ij}, -\beta p_j \rightarrow p_j, \tau \rightarrow \beta\tau$. In new variables, the generating functional and operators in the Euclidean–Heisenberg representation have the form $Z[p] = \text{Sp} \exp[\mathcal{H}(p)]$ and $\hat{\sigma}_j(\vec{1}, \tau) = \exp(-\tau\mathcal{H})\sigma_j(\vec{1})\exp(\tau\mathcal{H})$, respectively, where $\tau \in [0, 1]$.

In order to derive differential equations for the generating functional, we reveal the dependence on p in relation (5) and find the explicit form of this dependence. For this purpose, we perform transformation from operators in the Euclidean–Heisenberg representation to operators in the interaction representation $\sigma_j(\vec{1}, \tau) = \exp(-\tau\mathcal{H}_0)\sigma_j(\vec{1})\exp(\tau\mathcal{H}_0)$. In the interaction representation the Hamiltonian \mathcal{H}' is regarded as a perturbation. The transformation from operators in the Euclidean–Heisenberg representation to operators $\sigma_j(\vec{1}, \tau)$ in the interaction representation is determined by the evolution operator $U(\tau)$ [23]

$$\hat{\sigma}_j(\vec{1}, \tau) = U^{-1}(\tau)\sigma_j(\vec{1}, \tau)U(\tau).$$

The evolution operator represents the dependence on p by the form

$$U(\tau) = \exp(-\tau\mathcal{H}_0)\exp(\tau\mathcal{H}) = \mathbf{T} \exp \left[\int_0^\tau \mathcal{H}'(\tau') d\tau' \right],$$

where $\mathcal{H}'(\tau) = \exp(-\tau\mathcal{H}_0)\mathcal{H}'\exp(\tau\mathcal{H}_0)$ is the Hamiltonian (4) with the auxiliary fields p in the interaction representation; \mathbf{T} is the time-ordering operator. If time variables τ are coincided, then

$$\mathbf{T}\{A, B\} = 1/2[AB + (-1)^{\text{deg } A \cdot \text{deg } B} BA].$$

Differentiation of the evolution operator $U(1)$ at $\tau = 1$ with respect to the fields p gives

$$\begin{aligned} \frac{\delta}{\delta p_{j_1}(\vec{1}, \tau_1)} \cdots \frac{\delta}{\delta p_{j_n}(\vec{n}, \tau_n)} U(1) &= \mathbf{T} \left\{ \sigma_{j_1}(\vec{1}, \tau_1) \cdots \sigma_{j_n}(\vec{n}, \tau_n) \exp \left[\int_0^1 \mathcal{H}'(\tau) d\tau \right] \right\} \\ &= U(1)\mathbf{T}[\hat{\sigma}_{j_1}(\vec{1}, \tau_1) \cdots \hat{\sigma}_{j_n}(\vec{n}, \tau_n)]. \end{aligned} \quad (7)$$

Since the differential operators are noncommutative, the time variables τ_j are added in the fields p_j . Variables τ_j can be regarded as Feynman's ordering variables [24]. By virtue of this, we write time variables in the fields p_j in all following equations. Time variables can be dropped if and only if the Lie algebra \mathcal{L} is commutative. This case shall be considered in section 3.2, in which Cartan's subalgebra is represented as an independent Lie algebra.

Operator products in relation (7) belong to the universal enveloping algebra $\mathcal{U}(\mathcal{L})$ [25]. This relation makes possible to represent \mathbf{T} -ordering products of operators $\hat{\sigma}_j$ belonging to $\mathcal{U}(\mathcal{L})$ by differential operators on a functional algebra. We define this functional algebra as the commutative algebra \mathcal{A} of regular functionals $R \in \mathcal{A}$ over the ring $\mathcal{F}^{(0)}$ of functions $p_j(\vec{1}, \tau)$. Regular functionals $R \in \mathcal{A}$ can be given in the form of the power series with respect to the fields $p_j(\vec{1}, \tau) \in \mathcal{F}^{(0)}$

$$\begin{aligned} R[p] &= \sum_{n=0}^{\infty} \sum_{j_1, \dots, j_n} \sum_{\vec{1}, \dots, \vec{n}} \int_0^1 \cdots \int_0^1 Y_{j_1, \dots, j_n}(\vec{1}, \dots, \vec{m}; \tau_1, \dots, \tau_m) \\ &\quad \times p_{j_1}(\vec{1}, \tau_1) \cdots p_{j_n}(\vec{n}, \tau_n) d\tau_1 \cdots d\tau_n, \end{aligned} \quad (8)$$

where $m \geq n$, $Y_{j_1, \dots, j_n}(\vec{1}, \dots, \vec{m}; \tau_1, \dots, \tau_m)$ are functions of m space and m time variables.

These functions belong to the smooth envelope of the tensor product of m rings $\overline{\otimes}_m \mathcal{F}_m^{(0)}$. We require that integrals are of finite values and the series is convergent. We can define the summation $\mathcal{A} \oplus \mathcal{A} \rightarrow \mathcal{A}$, multiplication $\mathcal{A} \otimes \mathcal{A} \rightarrow \mathcal{A}$, $\mathcal{A} \otimes \mathcal{F}^{(0)} \rightarrow \mathcal{A}$ and differential operations on the $\mathcal{F}^{(0)}$ -algebra \mathcal{A} . The summation and multiplication operations in the algebra

\mathcal{A} are defined as term-by-term summation and multiplication of the power series, respectively. According to [19–21], differentiation is the special case of the $\mathcal{F}^{(0)}$ -homomorphism. The differentiation of the regular functional $R[p]$ with respect to the field $p_i(\vec{l}, \tau_i)$ is reduced to the elimination of the field $p_i(\vec{l}, \tau_i)$ and to the dropping out the sum and the integral over variables \vec{l}, τ_i in the power series (8)

$$\frac{\delta R[p]}{\delta p_i(\vec{l}, \tau_i)} = \sum_{n=0}^{\infty} \sum_{j_1, \dots, \hat{i}, \dots, j_n} \sum_{\vec{l}_1, \dots, \hat{\vec{l}}, \dots, \vec{l}_n} \int_0^1 \cdots \int_0^1 Y_{j_1, \dots, j_n}(\vec{l}, \dots, \vec{m}; \tau_1, \dots, \tau_n) \times \underbrace{p_{j_1}(\vec{l}_1, \tau_1) \cdots \hat{p}_i(\vec{l}, \tau_i) \cdots p_{j_n}(\vec{l}_n, \tau_n)}_{n-1} d\tau_1 \cdots d\hat{\tau}_i \cdots d\tau_n, \tag{9}$$

where the mark $\hat{}$ points out that the given variable must be dropped. The summation over indices $j_1, \dots, \hat{i}, \dots, j_n$ in relation (9) is performed over all sets $\{\hat{i}, j_2, \dots, j_n\}, \dots, \{j_1, \dots, j_{n-1}, \hat{i}\}$.

After averaging with the operator $\exp(\mathcal{H})$, relation (7) can be used for representation of equation (6) in the form of differential functional equations. Taking into account the explicit form of the Hamiltonian \mathcal{H} , defined by relations (1), (2) and (4), the commutation relations (3) and relation (7), we substitute of differential operators for operators $\hat{\sigma}_j$ in the Euclidean–Heisenberg representation in equation (6) and obtain differential functional equations

$$\frac{\partial}{\partial \tau} \frac{\delta Z[p]}{\delta p_j(\vec{l}, \tau)} = \sum_{i,m} [b_i(\vec{l}) + p_i(\vec{l}, \tau)] C_{ij}^m \frac{\delta Z[p]}{\delta p_m(\vec{l}, \tau)} + \sum_{i,n,m,\vec{l}'} C_{nj}^m [V_{in}(\vec{l}' - \vec{l}) + \kappa_{in} V_{ni}(\vec{l} - \vec{l}')] \frac{\delta^2 Z[p]}{\delta p_i(\vec{l}', \tau) \delta p_m(\vec{l}, \tau)}. \tag{10}$$

In the general case, solutions of the functional equation (10) belong to a module over the algebra \mathcal{A} . Besides the derivation of the functional equation (10), relation (7) can be used for the derivation of the following proposition—the functional $Z[p]$ generates temperature Green’s functions without vacuum loops [23]

$$G_{j_1 \dots j_n}(\vec{l}_1, \dots, \vec{l}_n, \tau_1, \dots, \tau_n) \equiv \langle\langle \mathbf{T} \hat{\sigma}_{j_1}(\vec{l}_1, \tau_1) \cdots \hat{\sigma}_{j_n}(\vec{l}_n, \tau_n) \rangle\rangle = Z^{-1} \frac{\delta^n Z[p]}{\delta p_{j_1}(\vec{l}_1, \tau_1) \cdots \delta p_{j_n}(\vec{l}_n, \tau_n)} \Big|_{p \rightarrow 0}, \tag{11}$$

where $\langle\langle \cdots \rangle\rangle$ denotes averaging or the trace operation Sp calculated with the operator $\exp(\mathcal{H})/\text{Sp} \exp(\mathcal{H})$.

3. Diagram expansion

We will find the solution of equation (10) in the form of the power series expansion for the functional $Z[p]$ with respect to the interaction V_{ij} and fields p . Each term of the series corresponds to a diagram, therefore, this power series expansion is known as the diagram expansion. In order to find the diagram expansion, we substitute the functional $W[p]$ for the functional $Z[p]$. $W[p]$ is the generating functional for the connected Green functions without the interaction V_{ij} and is defined as [23]

$$Z[p] = \exp \left[\sum_{\substack{\vec{l}, \vec{l}' \\ i,j}} \int_0^1 \frac{\delta}{\delta p_i(\vec{l}, \tau)} V_{ij}(\vec{l} - \vec{l}') \frac{\delta}{\delta p_j(\vec{l}', \tau)} \right] \exp W[p] d\tau. \tag{12}$$

Substituting $W[p]$ for $Z[p]$ in equation (10), we get equations for the functional $W[p]$ without V_{ij} terms. These equations are given on a single crystal lattice site

$$\left[\frac{\partial}{\partial \tau} - \sum_i C_{ij}^j u_i(\vec{1}, \tau) \right] \frac{\delta W[p]}{\delta p_j(\vec{1}, \tau)} = \sum_{i,m(\neq j)} C_{ij}^m u_i(\vec{1}, \tau) \frac{\delta W[p]}{\delta p_m(\vec{1}, \tau)}, \quad (13)$$

where $u_i(\vec{1}, \tau) = b_i(\vec{1}) + p_i(\vec{1}, \tau)$.

The diagram expansion for $W[p]$ has the form of the power series with respect to the fields p

$$W[p] = \sum_{n=0}^{\infty} \sum_{\substack{\vec{1} \\ j_1, \dots, j_n}} \int_0^1 \cdots \int_0^1 \Gamma_{j_1, \dots, j_n}(\vec{1}, \tau_1 \dots \tau_n) p_{j_1}(\vec{1}, \tau_1) \cdots p_{j_n}(\vec{1}, \tau_n) d\tau_1 \cdots d\tau_n. \quad (14)$$

Coefficients $\Gamma_{j_1, \dots, j_n}(\vec{1}, \tau_1 \dots \tau_n)$ are given by derivatives of $W[p]$ with respect to the fields p in the limit $p = 0$

$$\Gamma_{j_1, \dots, j_n}(\vec{1}, \tau_1 \dots \tau_n) = \left. \frac{\delta^n W[p]}{\delta p_{j_1}(\vec{1}, \tau_1) \cdots \delta p_{j_n}(\vec{1}, \tau_n)} \right|_{p \rightarrow 0}.$$

In general, coefficients $\Gamma_{j_1, \dots, j_n}(\vec{1}, \tau_1 \dots \tau_n)$ are distributions. If $\Gamma_{j_1, \dots, j_n}(\vec{1}, \tau_1 \dots \tau_n)$ are smooth functions complying with requirements of series convergence and integral finiteness in relation (14), then the functional $W[p]$ belongs to the algebra \mathcal{A} . Otherwise, $W[p]$ belongs to an \mathcal{A} -module. In order to find these coefficients, we single out Cartan's subalgebra H in the Lie algebra \mathcal{L} . In the general case, Cartan's subalgebra is nilpotent, but we assume that H is commutative with dimension of $\dim H = r$ and with the basis $\{\sigma_j^{(H)}(\vec{1})\}$ [26–28]. For quantum systems at the thermodynamic equilibrium with the Hamiltonian, described by relation (2), the subalgebra H corresponds to the set of operators of observable variables. External fields $b_j(\vec{1}) \equiv b_j^{(H)}(\vec{1})$ and derivatives $\delta W[p]/\delta p_j(\vec{1}, \tau)$ corresponding to these observable variables, in general, differ from zero values. Therefore, we shall say that the auxiliary field $p_j(\vec{1}, \tau)$ corresponding to the operator $\sigma_j^{(H)} \in H$ are Cartan's field $p_j^{(H)}(\vec{1}, \tau)$. Auxiliary fields differed from $p_j^{(H)}(\vec{1}, \tau)$ are denoted by $\bar{p}_j(\vec{1}, \tau)$. Thus, the ring $\mathcal{F}^{(0)}(p)$ can be decomposed with the direct sum $\mathcal{F}^{(0)}(p) = \mathcal{F}^{(0)}(p^{(H)}) \oplus \mathcal{F}^{(0)}(\bar{p})$.

After determination of Cartan's subalgebra, we perform the root decomposition of the Lie algebra \mathcal{L} relative to Cartan's subalgebra H : $\mathcal{L} = \oplus_{\alpha} \mathcal{L}_{\alpha}$, $H = \mathcal{L}_0$ [26–28]. Roots α are 1-forms belonging to the dual space H^* and form the root system $\Delta = \{\alpha \in H^* | \mathcal{L}_{\alpha} \neq 0\}$. If \mathcal{L} is a superalgebra, then $\mathcal{L} = \mathcal{L}_0 \oplus \mathcal{L}_1$, where $\deg \mathcal{L}_0 = 0$ and $\deg \mathcal{L}_1 = 1$ and the root system has the form $\Delta_0 \cup \Delta_1$ [28]. Δ_0 is the root system of the algebra \mathcal{L}_0 and Δ_1 is the system of weights of the representation of the algebra \mathcal{L}_0 on the \mathcal{L}_0 -module \mathcal{L}_1 . Accordingly, Δ_0 is called the system of even and Δ_1 that of odd roots. Since the subalgebra H is commutative, then the adjoint representation $\text{ad}(\sigma_i^{(H)})\sigma_k^{(\alpha)} \equiv [\sigma_i^{(H)}, \sigma_k^{(\alpha)}]$ on spaces \mathcal{L}_{α} ($\sigma_k^{(\alpha)} \in \mathcal{L}_{\alpha}$) has the triangular form, and we can choose the basis of $\sigma_j^{(\alpha)}$, which is satisfied by the following conditions:

$$\begin{aligned} \text{ad}(\sigma_i^{(H)})\sigma_1^{(\alpha)} &= C_{i1}^1 \sigma_1^{(\alpha)} \\ \text{ad}(\sigma_i^{(H)})\sigma_2^{(\alpha)} &= C_{i2}^1 \sigma_1^{(\alpha)} + C_{i2}^2 \sigma_2^{(\alpha)} \\ &\dots \\ \text{ad}(\sigma_i^{(H)})\sigma_n^{(\alpha)} &= \sum_{j=1}^n C_{in}^j \sigma_j^{(\alpha)}, \end{aligned} \quad (15)$$

where diagonal coefficients C_{ij}^j do not depend on the index j , i.e. $C_{i1}^1 = \dots = C_{in}^n$ for the given root subspace \mathcal{L}_α . After the root decomposition performing, roots α and diagonal coefficients $C_{ij_\alpha}^{j_\alpha}$, defined by commutation relations (3), are connected by the relation $\alpha(\sigma_i^{(H)}) = C_{ij_\alpha}^{j_\alpha}$, where the index j_α corresponds to the root α [26, 27]. We consider the case of the algebra \mathcal{L} , for which for every root α_k the opposite root $-\alpha_k$ exists.

We find coefficients Γ_{j_1, \dots, j_n} in relation (14) by means of a two-step procedure. At the first step, we use a recursion relation and reduce derivatives with respect to non-Cartan's fields—we express derivatives of W with respect to the fields $\bar{p}_i(\vec{1}, \tau)$ by derivatives of W with respect to the Cartan fields $p_j^{(H)}(\vec{1}, \tau)$. Then, we perform passage to the limit $\bar{p} \rightarrow 0$. At the second step, we calculate derivatives of W with respect to the Cartan fields $p_j^{(H)}(\vec{1}, \tau)$ at the limit $p_j^{(H)} \rightarrow 0$.

3.1. The first step: expression of functional derivatives via derivatives with respect to Cartan's fields

Derivatives of W with respect to the fields $\bar{p}_i(\vec{1}, \tau)$ corresponding to operators $\sigma_j \notin H$ can be found by a recursion procedure following from equation (13). Let σ_j be the basis vector in relation (15) with the root $\alpha_j \neq 0$. Then, taking into account that $\alpha(\sigma_i^{(H)}) = C_{ij_\alpha}^{j_\alpha}$ and solving equation (13) as the differential equation with respect to τ , we obtain

$$\frac{\delta W[p]}{\delta \bar{p}_j(\vec{1}, \tau)} = C_j \exp \left[\int_0^\tau g_j(\vec{1}, \tau') d\tau' \right] + \int_0^\tau d_j(\vec{1}, \tau, \tau') \sum_{i, m (\neq j)} C_{ij}^m u_i(\vec{1}, \tau') \frac{\delta W[p]}{\delta p_m(\vec{1}, \tau')} d\tau', \tag{16}$$

where

$$d_j(\vec{1}, \tau, \tau') = \exp \left[\int_{\tau'}^\tau g_j(\vec{1}, \bar{\tau}) d\bar{\tau} \right] \theta(\tau - \tau')$$

is the kernel of the integral operator inverse to the operator $\partial/\partial\tau - g_j(\vec{1}, \tau)$:

$$\left[\frac{\partial}{\partial\tau} - g_j(\vec{1}, \tau) \right] d_j(\vec{1}, \tau, \tau') = \delta(\tau - \tau'), \tag{17}$$

$g_j(\vec{1}, \tau) = \sum_{i=1}^r \alpha_j(\sigma_i^{(H)}) u_i(\vec{1}, \tau)$, $\sigma_i^{(H)}$ is the basis vector of Cartan's subalgebra, C_j is an arbitrary functional independent of the variable τ and

$$\theta(\tau) = \begin{cases} 1, & \tau \geq 0 \\ 0, & \tau < 0. \end{cases}$$

Let us make the extension of $d_j(\vec{1}, \tau, \tau')$ on $\tau' > \tau$ in the range $\tau, \tau' \in [-1, 1]$ and the periodic extension on other values of τ, τ' in relation (16). In order to eliminate the arbitrariness of the functional C_j , we perform this extension so as at $\bar{p} \rightarrow 0$ the second derivatives of W with respect to the fields \bar{p}_i, \bar{p}_j with $\alpha_i = -\alpha_j$ have the form

$$\begin{aligned} \frac{\delta^2 W[p]}{\delta \bar{p}_i(\vec{1}, \tau') \delta \bar{p}_j(\vec{1}, \tau)} &= A_1 \exp \left[\int_{\tau'}^\tau g_j(\vec{1}, \bar{\tau}) d\bar{\tau} \right] \sum_m C_{ij}^m \frac{\delta W[p]}{\delta p_m(\vec{1}, \tau')} \quad (\tau > \tau') \\ \frac{\delta^2 W[p]}{\delta \bar{p}_i(\vec{1}, \tau') \delta \bar{p}_j(\vec{1}, \tau)} &= \kappa_{ij} \frac{\delta^2 W[p]}{\delta \bar{p}_j(\vec{1}, \tau) \delta \bar{p}_i(\vec{1}, \tau')} \\ &= -A_2 \exp \left[\int_{\tau'}^\tau g_j(\vec{1}, \bar{\tau}) d\bar{\tau} \right] \sum_m C_{ij}^m \frac{\delta W[p]}{\delta p_m(\vec{1}, \tau)} \quad (\tau < \tau'). \end{aligned} \tag{18}$$

We take into account that, in this case, $g_i = -g_j$, $C_{ij}^m = -\kappa_{ij}C_{ji}^m$, $\delta W[p]/\delta p_m(\vec{1}, \tau) \neq 0$ is the derivative with respect to Cartan's field and this derivative is independent of the variable τ due to the commutativity of Cartan's subalgebra. Then, the coefficients A_1, A_2 in relation (18) are uniquely determined by the requirement that, in accordance with relation (17), steps of the function $d_j(\vec{1}, \tau, \tau')$ at $\tau = \tau'$ and at $\tau = \tau' - 1$ are equal to 1 and $\kappa_{ij} = \kappa_{jj}$, respectively,

$$A_1 - A_2 = 1, \quad A_1 \exp[f_j(\vec{1})] - A_2 \exp[-f_j(\vec{1})] = -\kappa_{jj},$$

where $f_j(\vec{1}) = \sum_{l=1}^r \alpha_j(\sigma_l^{(H)})b_l(\vec{1})$. We obtain $A_1 = -\kappa_{jj}n_j(f_j(\vec{1}))$, $A_2 = \kappa_{jj}n_j(-f_j(\vec{1}))$ and define the propagator

$$\begin{aligned} \bar{D}_j(\vec{1}, \tau, \tau') &= [A_1 d_j(\vec{1}, \tau, \tau') - A_2 d_j(\vec{1}, \tau', \tau)] \\ &= [-n_j(f_j(\vec{1}))\theta(\tau - \tau') + n_j(-f_j(\vec{1}))\theta(\tau' - \tau)]\kappa_{jj} \exp \left[\int_{\tau'}^{\tau} g_j(\vec{1}, \bar{\tau}) d\bar{\tau} \right], \end{aligned} \quad (19)$$

where $n_j(x) = (\exp x - \kappa_{jj})^{-1}$. Then, relation (16) is written in the form

$$\frac{\delta W[p]}{\delta \bar{p}_j(\vec{1}, \tau)} = \int_0^1 \sum_{i, m(\neq j)} C_{ij}^m \bar{D}_j(\vec{1}, \tau, \tau') u_i(\vec{1}, \tau') \frac{\delta W[p]}{\delta p_m(\vec{1}, \tau')} d\tau'. \quad (20)$$

Derivatives $\delta^n W[p]/\delta \bar{p}_{j_1} \cdots \delta \bar{p}_{j_n}$ can be found by the recursion procedure based on relation (20). In order to clarify how derivatives of W with respect to the fields $\bar{p}_i(\vec{1}, \tau)$ are substituted by derivatives of W with respect to Cartan's fields, we differentiate relation (20) with respect to an arbitrary non-Cartan's field \bar{p}_k

$$\begin{aligned} \frac{\delta^2 W[p]}{\delta \bar{p}_k(\vec{1}, \tau') \delta \bar{p}_j(\vec{1}, \tau)} &= \int_0^1 \sum_{i, m(\neq j)} C_{ij}^m \frac{\delta \bar{D}_j(\vec{1}, \tau, \tau'')}{\delta \bar{p}_k(\vec{1}, \tau')} u_i(\vec{1}, \tau'') \frac{\delta W[p]}{\delta p_m(\vec{1}, \tau'')} d\tau'' \\ &+ \sum_{m(\neq j)} C_{kj}^m \bar{D}_j(\vec{1}, \tau, \tau') \frac{\delta W[p]}{\delta p_m(\vec{1}, \tau')} \\ &+ \int_0^1 \sum_{i, m(\neq j)} \kappa_{ik} C_{ij}^m \bar{D}_j(\vec{1}, \tau, \tau'') u_i(\vec{1}, \tau'') \frac{\delta^2 W[p]}{\delta \bar{p}_k(\vec{1}, \tau') \delta p_m(\vec{1}, \tau'')} d\tau''. \end{aligned} \quad (21)$$

In relation (21) at $\bar{p} \rightarrow 0$, the third summand possesses terms with $u_i = b_i(\vec{1})$ corresponded to Cartan's fields. Hence, in the coefficient C_{ij}^m indices j and m belong to the common root space \mathcal{L}_α . By virtue of the triangular form of the adjoint representation (15), in the third summand the derivative $\delta^2 W[p]/\delta \bar{p}_k \delta p_m$ possesses the index $m < j$. If it is necessary, using relation (21), we can repeat the reduction process for the derivative $\delta^2 W[p]/\delta \bar{p}_k \delta p_m$ and express the second derivative $\delta^2 W[p]/\delta \bar{p}_k \delta \bar{p}_j$ by first derivatives of $W[p]$. Taking into account that for non-Cartan's fields $\delta W[p]/\delta \bar{p}_m|_{\bar{p} \rightarrow 0} = 0$, the derivative $\delta^2 W[p]/\delta \bar{p}_k \delta \bar{p}_j|_{\bar{p} \rightarrow 0}$ is expressed by first derivatives of $W[p]$ with respect to Cartan's fields. For the case of derivatives of higher orders, the analogous recursion procedure of the reduction of derivatives $\delta^n W[p]/\delta \bar{p}_{j_1} \cdots \delta \bar{p}_{j_n}$ to derivatives with respect to Cartan's fields can be used. Thus, after realization of the recursion procedure in order to calculate coefficients Γ_{j_1, \dots, j_n} , we must find derivatives of $W[p]$ with respect to Cartan's fields $p_j^{(H)}(\vec{1}, \tau)$.

3.2. The second step: calculation of functional derivatives with respect to Cartan's fields

In the absence of an interaction ($V_{ij} = 0$) at the limit $\bar{p} \rightarrow 0$ and at the thermodynamic equilibrium, the external fields $\bar{b}_j(\vec{1})$ are zero and the Hamiltonian \mathcal{H} given by relation (1)

describes systems with commutative operators. For such quantum systems, the functional $W[p]$ can be found by a direct calculation. Taking into account definitions (5) and (12) of $Z[p]$ and $W[p]$, respectively, and the fact that for the commutative Cartan subalgebra H , the fields $p_j^{(H)}$ are independent of τ , consequently, the variable τ can be dropped and $u_j^{(H)}(\vec{1}, \tau) = b_j^{(H)}(\vec{1}) + p_j^{(H)}(\vec{1}) = u_j^{(H)}(\vec{1})$, we obtain

$$\begin{aligned} W[p^{(H)}] &= \ln \text{Sp} \exp \left\{ \sum_{\vec{1}, j} u_j^{(H)}(\vec{1}, \tau) \sigma_j^{(H)}(\vec{1}) \right\} \\ &= \sum_{\vec{1}} \ln \sum_{i=1}^m \prod_j \exp [u_j^{(H)}(\vec{1}) \rho_j^{(i)}] \equiv \sum_{\vec{1}} F_\rho[u^{(H)}], \end{aligned} \quad (22)$$

where ρ is the representation of the subalgebra H , in whose operators $\sigma_j^{(H)}(\vec{1})$ have the diagonal form $\text{diag}[\rho_j^{(1)}, \dots, \rho_j^{(m)}]$; $i = 1, 2, \dots, m$ is the index of spectral states; F_ρ is the free energy. Then, in the expansion (14) coefficients Γ_{j_1, \dots, j_n} with indices j_1, \dots, j_n corresponding to Cartan's fields, denoted as $\Gamma_{j_1, \dots, j_n}^{(H)}$, can be written in the form

$$\Gamma_{j_1, \dots, j_n}^{(H)}(\vec{1}) = \left. \frac{\delta^n F_\rho[u^{(H)}]}{\delta p_{j_1}^{(H)}(\vec{1}) \dots \delta p_{j_n}^{(H)}(\vec{n})} \right|_{p^{(H)} \rightarrow 0} = \frac{\partial^n F_\rho[b^{(H)}]}{\partial b_{j_1}^{(H)}(\vec{1}) \dots \partial b_{j_n}^{(H)}(\vec{n})}. \quad (23)$$

For instance, consider the special case of $\mathcal{L} = so(3)$. The Cartan subalgebra is formed by the operator S_z , $H = \text{Span}\{S_z\}$, and the representation ρ is realized by diagonal $(2l+1) \times (2l+1)$ matrices. The linear coefficient $\Gamma_j^{(H)}(\vec{1})$ ($j = z$) of the expansion given by relation (23) are expressed in terms of the Brillouin function [7–9]

$$\Gamma_j^{(H)}(\vec{1}) = l B_l(l b_j^{(H)}(\vec{1})).$$

Then, coefficients Γ_{j_1, \dots, j_n} of higher orders are expressed in terms of derivatives of the Brillouin function with respect to the external field $b_j^{(H)}(\vec{1}) = b_z(\vec{1})$.

3.3. Diagram expansion in imaginary time-dependent variables

3.3.1. Propagators. In order to calculate coefficients $\Gamma_{j_1, \dots, j_n}(\vec{1}, \tau_1 \dots \tau_n)$ in the expansion (14), we must use relation (20) several times (if it is necessary) and, then, pass to the limit $\{p_j\} \rightarrow 0$. We assign the line with the arrow directed from the vertex with the time τ to the vertex with the time τ' (figure 1(a)) to the limit value of the propagator given by relation (19):

$$D_j(\vec{1}, \tau - \tau') = \bar{D}_j(\vec{1}, \tau, \tau')|_{p \rightarrow 0}. \quad (24)$$

According to relation (19), the root α_j can be associated with the propagator D_j . It is a need to note that the extension of d_j on $\tau' > \tau$ in relation (16) allows us to reduce the number of propagators, which must be accounted in the diagram expansion. If $\alpha_k = -\alpha_j$, then instead of the propagator D_k we can use the propagator D_j with $\alpha_j > 0$ and with opposite arrow direction ($\tau - \tau' < 0$) in the expansion. This corresponds to the system of operator majorities [12–14].

3.3.2. Vertices. Propagators and interaction lines are tied by vertices in diagrams. There are six vertex types. The first five types correspond to factors arising from differentiation of the functional $W[p]$ with respect to the field $p_i(\vec{1}, \tau)$ (figure 1(b)). The field $p_i(\vec{1}, \tau)$ is displayed as a segment of a wavy line with the index i . In accordance with relation (20), these factors depend on indices of the differentiating field, incoming and outgoing propagators and have

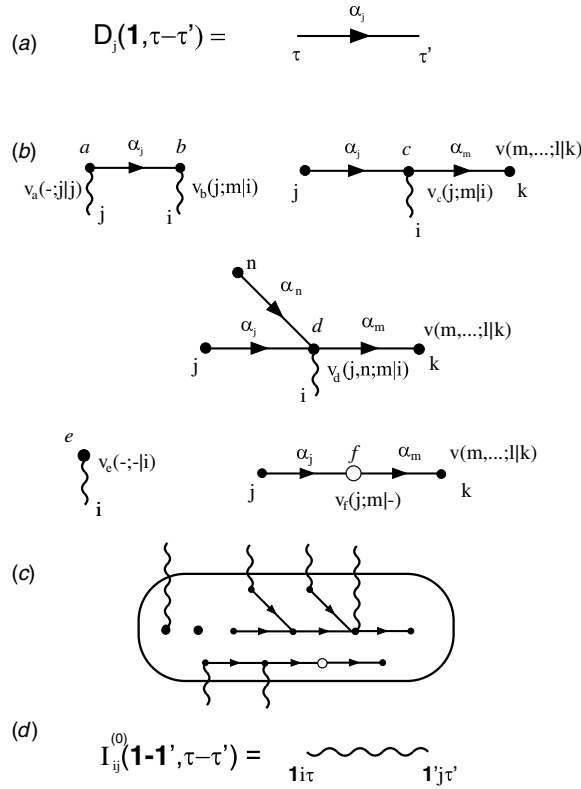

Figure 1. (a) Propagators $D_j(\vec{1}, \tau - \tau')$, (b) vertices, (c) example of a block and (d) interaction line $I_{ij}^{(0)}(\vec{1} - \vec{1}', \tau - \tau')$.

the general form $v(\{j\}; m|i)$, where $\{j\}$ is the set of indices of propagators incoming into the vertex, m is the index of propagator outgoing from the vertex or the index of Cartan's field p_m in the coefficient $\Gamma_{j_1, \dots, j_n}^{(H)}$ defined by relation (23), i is the index of the field $p_i(\vec{1}, \tau)$. If an index is absent in the vertex, then we shall write the dash at this place.

We obtain the following types of vertices. From relation (20), one can see that the start and end points of propagators correspond to vertices. We shall call that the vertex is of the type a , if the vertex has one outgoing propagator and has not any incoming ones. The vertex factor is $v_a(-; j|j) = 1$. The vertex of the type b with the factor $v_b(j; m|i) = C_{ij}^m$ has one incoming propagator with the index j and no outgoing ones. The index m corresponds to an index of the coefficient $\Gamma_{j_1, \dots, j_n}^{(H)}$. The c -vertex is obtained as a result of differentiation of \bar{D}_j -propagator with respect to Cartan's field and as a result of differentiation of the variable u_i with respect to non-Cartan's field in relation (20). One propagator comes in (the index j) and one propagator goes out (the index m) from the c -vertex. The corresponding factor is $v_c(j; m|i) = C_{ij}^m$. The vertex of the d -type is characterized by two incoming propagators and one outgoing propagator. The d -vertex is gotten as a result of the twofold action of the recursion procedure based on relation (20). After permutation of derivatives of $W[p]$ with respect to fields $\bar{p}_k(\vec{1}, \tau')$, $p_m(\vec{1}, \tau'')$ in the third summation in relation (21), end points of two incoming propagators and the start point of the outgoing propagator have equal time variables and must be tied. The factor corresponding to the d -vertex is equal to $v_d(j, n; m|i) = \kappa_{jn} \sum_s C_{ij}^s C_{sn}^m$,

where j, n are indices of incoming propagators, m is the index of the outgoing propagator and i is the index of the field p_i . e -Vertices are associated with differentiation with respect to Cartan's fields $p_i^{(H)}$ on the second step of the calculation of functional derivatives (section 3.2). The vertex factor is $v_e(-; -|i) = 1$. Finally, we introduce the vertex of the type f , which does not correspond to a differentiation and is caused by Cartan's variable u_i in relation (20). One propagator comes in and one propagator goes out from the f -vertex. Propagators have identical roots, $\alpha_m = \alpha_j$. The vertex factor is equal to $v_f(j; m|-) = \sum_i C_{ij}^m b_i(\vec{1})$. In accordance with the triangular form of the adjoint representation (15) and the condition $m \neq j$ given by relation (20), the index m (the index of the outgoing propagator) in the f -vertex is less than j (the index of the incoming propagator), $m < j$. In cases of c -, d -, f -vertices, the summation over the index of the outgoing propagator and indices of neighboring vertices must be done. In other words, the summation over m must be performed, where m is the common index of the propagator outgoing from the vertex $v(\dots; m|\dots)$, the root α_m of the propagator and the propagator incoming into the neighboring vertex $v(m, \dots; l|k)$ (figure 1(b)). In the case of the b -vertex with the factor $v_b(j; m|i)$, the summation must be performed over the common index m of the vertex and one of the indices of the coefficient $\Gamma_{j_1, \dots, j_n}^{(H)}$ given by relation (23).

After definition of vertices, we can formulate the law of conservation of roots. The root $\alpha_i^{(\text{field})}$ can be assigned to the differentiation of $W[p]$ with respect to the field $p_i(\vec{1}, \tau)$. Roots $\alpha_j^{(\text{in})}$ of propagators incoming into the vertex and roots $\alpha_m^{(\text{out})}$ of outgoing propagators are given with '+' and '-' signs, respectively. Then, taking into account the property of the root decomposition of Lie algebras [26–28]

$$[\sigma^{(\alpha)}, \sigma^{(\beta)}] \in \mathcal{L}_{\alpha+\beta},$$

from relation (20) we obtain the law of conservation of roots in a vertex

$$\alpha_i^{(\text{field})} + \sum_j \alpha_j^{(\text{in})} - \alpha_l^{(\text{out})} = 0. \quad (25)$$

In the case of e -vertices, relation (25) is trivial. For f -vertices, the root $\alpha_i^{(\text{field})}$ must be dropped out.

3.3.3. Blocks. As a result of the first step based on relation (20)—expression of functional derivatives of $W[p]$ in relation (14) via derivatives with respect to Cartan's fields—we obtain a diagram consisting of n isolated parts. These parts are e -vertices, single propagators and a set of propagators tied by c -, d -, f -vertices. The number of isolated parts n is equal to the number of differentiations of $W[p]$ with respect to Cartan's fields or, equivalently, to the number of indices of the coefficient $\Gamma_{j_1, \dots, j_n}^{(H)}(\vec{1})$ in relation (23). We confine these parts in a block (figure 1(c)). According to relation (23), we assign the factor $\Gamma_{j_1, \dots, j_n}^{(H)}(\vec{1})$ to the block of n parts. In blocks all parts have equal space variables. Each part with propagators tied by vertices ends off a b -vertex. Indices j_k of the factor $\Gamma_{j_1, \dots, j_n}^{(H)}(\vec{1})$ correspond to indices i of e -vertices, $v_e(-; -|i)$, and to indices m of b -vertices, $v_b(j; m|i)$. In the case of b -vertices, it is the need to perform the summation over indices m .

3.3.4. Interaction lines. Returning to the functional $Z[p]$ given by relation (12), we can see that the operation $\delta/\delta p_i(\vec{1}, \tau) V_{ij}(\vec{1} - \vec{1}') \delta/\delta p_j(\vec{1}', \tau)$ adds interaction lines $I_{ij}^{(0)}(\vec{1} - \vec{1}', \tau - \tau') = V_{ij}(\vec{1} - \vec{1}') \delta(\tau - \tau')$ connected couples of vertices (figure 1(d)). Roots $\alpha_i^{(\text{field})}$ and $\alpha_j^{(\text{field})}$ associated with fields p_i and p_j , respectively, can be assigned to end points of the interaction line $I_{ij}^{(0)}$. So, the law of conservation of roots in a vertex (25) holds.

The diagram expansion for $Z[p]$ has the form of the power series

$$Z[p] = \sum_{n=0}^{\infty} \sum_{\substack{\vec{1}, \dots, \vec{n} \\ j_1, \dots, j_n}} \int_0^1 \cdots \int_0^1 Q_{j_1, \dots, j_n}(\vec{1}, \dots, \vec{n}, \tau_1, \dots, \tau_n) \\ \times p_{j_1}(\vec{1}, \tau_1) \cdots p_{j_n}(\vec{n}, \tau_n) d\tau_1 \cdots d\tau_n, \quad (26)$$

where coefficients Q_{j_1, \dots, j_n} are proportional to temperature Green's function without vacuum loops (11). Taking into account relation (12) and calculating coefficients Γ_{j_1, \dots, j_n} in relation (14) by means of the two-step procedure, we determine coefficients Q_{j_1, \dots, j_n} in the diagram expansion. Each diagram corresponds to the analytical expression

$$Q_{j_1, \dots, j_n}(\vec{1}, \dots, \vec{n}, \tau_1, \dots, \tau_n) = \frac{P_s}{s!} \prod_L \sum_{\substack{\vec{1}, \dots, \vec{s} \\ \vec{1}', \dots, \vec{s}' \\ \{i, j, m\}}} \int_0^1 \cdots \int_0^1 I_{j_1 j_1'}^{(0)}(\vec{1} - \vec{1}', \tau_1 - \tau_1') \\ \times \cdots I_{j_s j_s'}^{(0)}(\vec{s} - \vec{s}', \tau_s - \tau_s') \prod_l D_{j_l}(\vec{1}_L, \tau_l - \tau_l') \\ \times \prod_{\mu \in \text{vertex}} v_{\mu}(\{j_r\}; m_r | i_r) \Gamma_{J_L}^{(H)}(\vec{i}_L) d\tau_1 \cdots d\tau_M, \quad (27)$$

where n is the number of external vertices related to fields p_j in the expansion (26). Interaction lines do not connect with external vertices. P_s is the number of topological equivalent diagrams. $2s$ is the number of inner vertices connected by interaction lines $I_{j_k j_k'}^{(0)}$. Integration is performed over $M = 2s + m_f$ time variables τ , where m_f is the number of f -vertices. $J_L = (j_1, \dots, j_{k_L})$ is the multi-index of the block L containing k_L parts. The block factor $\Gamma_{J_L}^{(H)}$ is determined by indices of b - and e -vertices. Products \prod_L and $\prod_{\mu \in \text{vertex}} v_{\mu}(\{j_r\}; m_r | i_r)$ are performed over all diagram blocks and all vertices, respectively. Indices of interaction lines and propagators are chosen in the set $\{i, j, m\} = \{i_1, \dots, j_1, \dots, m_1, \dots\}$ so that they coincide with the proper vertex indices and the law of conservation of roots in a vertex (25) holds. Time variables corresponded to the start and end points of propagators and interaction lines, which are tied in a vertex, must coincide. Moreover, space variables of interaction lines and propagators must coincide within blocks.

3.4. Diagram expansion in frequency-dependent variables

The frequency representation of the diagram expansion is more convenient for calculations. In order to perform this transformation, we determine the Fourier transforms of propagators (24) and interaction lines

$$D_j(\vec{1}, \omega_n) = \frac{1}{2} \int_{-1}^1 D_j(\vec{1}, \tau) \exp(-i\omega_n \tau) d\tau = \frac{[1 - (-1)^{n+1} \kappa_{jj}]}{2[i\omega_n - f_j(\vec{1})]}, \quad (28)$$

$$I_{jk}^{(0)}(\vec{1} - \vec{1}', \omega_n) = V_{jk}(\vec{1} - \vec{1}'), \quad (29)$$

where $\omega_n = \pi n$ ($n = 0, \pm 1, \dots$) are the Matsubara frequencies, $f_j(\vec{1}) = \sum_{l=1}^r \alpha_j(\sigma_l^{(H)}) b_l(\vec{1})$. The analytical expression of coefficients Q_{j_1, \dots, j_n} (27) in the frequency representation is written as

$$\begin{aligned}
Q_{j_1, \dots, j_n}(\vec{1}, \dots, \vec{n}, \omega_{n_1}, \dots, \omega_{n_n}) &= \frac{P_s}{s!} \prod_L \sum_{m_i} \sum_{\substack{\vec{1}, \dots, \vec{s} \\ \vec{1}', \dots, \vec{s}' \\ \{i, j, m\}}} I_{j_1 j_1'}^{(0)}(\vec{1} - \vec{1}', \omega_{m_1}) \cdots I_{j_s j_s'}^{(0)}(\vec{s} - \vec{s}', \omega_{m_n}) \\
&\times \prod_l D_{j_l}(\vec{1}_L, \omega_{m_l}) \prod_{\mu \in \text{vertex}} v_\mu(\{j_r\}; m_r | i_r) \prod_{\text{vertex}} \delta\left(\sum_l \omega_{m_l}\right) \Gamma_{J_L}^{(H)}(\vec{1}_L), \quad (30)
\end{aligned}$$

where \sum_{m_i} denotes the summation performed over all inner frequency variables. The term $\prod_{\text{vertex}} \delta(\sum_l \omega_{m_l})$ gives the frequency conservation in each vertex, i.e. the sum of frequencies of propagators and interaction lines, which come in and go out from a vertex, is equal to 0. The e -vertex can be connected with the single interaction line. In the analytical expression, this corresponds to the factor $\delta(\omega_m) = \delta_{m0}$.

Spectrum relations for excitations, relaxation times and other characteristics of the quantum system are given by poles of the two-site temperature Green functions (11) in the frequency representation under the analytical continuation

$$\begin{aligned}
i\omega_m &\rightarrow \omega + i\varepsilon \operatorname{sign} \omega \\
\delta_{m0} &\rightarrow (\omega + i\varepsilon \operatorname{sign} \omega)^{-1} \quad (\varepsilon \rightarrow 0). \quad (31)
\end{aligned}$$

4. Diagram expansion for quantum systems on topologically nontrivial manifolds

Differential functional equations (10) have been derived for models with the Hamiltonian (1) on a topologically trivial crystal lattice. The functional $Z[p]$ is defined as functional on fields $p_j(\vec{1}, \tau)$. These fields form the commutative ring of functions $\mathcal{F}^{(0)}$ for models with internal dynamic Lie algebras and the anticommutative ring for models with Lie superalgebras. The ring $\mathcal{F}^{(0)}$ produces a constant sheaf of functions. In order to generalize the diagram technique for models on topologically nontrivial manifolds, we ought to substitute in equation (10) the sheaf of function rings \mathcal{F} on the nontrivial manifold M for sheaf of functions $\mathcal{F}^{(0)} \subset \mathcal{F}$ and to perform substitution of continuous space variables for crystal lattice sites, $p_j(\vec{1}, \tau) \rightarrow p_j(\vec{r}, \tau)$. Then, the summation over crystal lattice sites is substituted by the integration over continuous space variables and regular functionals $R[p]$ (8) of the algebra \mathcal{A} can be written in the form

$$\begin{aligned}
R[p] &= \sum_{n=0}^{\infty} \sum_{j_1, \dots, j_n} \int_V \cdots \int_V \int_0^1 \cdots \int_0^1 Y_{j_1, \dots, j_n}(\vec{r}_1, \dots, \vec{r}_n; \tau_1, \dots, \tau_n) \\
&\times p_{j_1}(\vec{r}_1, \tau_1) \cdots p_{j_n}(\vec{r}_n, \tau_n) d\vec{r}_1 \cdots d\vec{r}_n d\tau_1 \cdots d\tau_n,
\end{aligned}$$

where $p_j(\vec{r}, \tau) \in \mathcal{F}$. The analogous transformation must be performed for the functionals $W[p]$ and $Z[p]$ given by relations (14) and (26), respectively.

In order to describe models on topologically nontrivial manifolds by equation (10), we require that, by analogy with fields $p_j(\vec{r}, \tau)$, external fields b_i and interactions V_{ik} belong to the sheaf of function rings \mathcal{F} , too. The generalized equation (10) cannot have any solutions or can possess one or many solutions. Solutions of the functional equation (10) exist if and only if Spencer's cohomologies are trivial [19–21]. This condition can impose constraint relations on fields b_i and on interactions V_{ik} of quantum systems on nontrivial manifolds. Singularities of many-valued solutions are determined by the acyclicity of Spencer's δ -complex.

Transformation to topologically nontrivial manifolds results in the existence of additional degrees of freedom and additional quantum excitations. The short exact sequence of sheaves of function rings on the manifold M

$$0 \rightarrow \mathcal{F}^{(0)} \xrightarrow{i} \mathcal{F} \xrightarrow{j} \mathcal{F}/\mathcal{F}^{(0)} \rightarrow 0,$$

where i is the injection, j is the epimorphism onto the factor sheaf $\mathcal{F}/\mathcal{F}^{(0)}$, induces the exact sequence of cohomology groups [29, 30]

$$\begin{aligned} 0 \rightarrow H^0(M, \mathcal{F}^{(0)}) \xrightarrow{i_*} H^0(M, \mathcal{F}) \xrightarrow{j_*} H^0(M, \mathcal{F}/\mathcal{F}^{(0)}) \xrightarrow{\delta_*} \\ \xrightarrow{\delta_*} H^1(M, \mathcal{F}^{(0)}) \xrightarrow{i_*} H^1(M, \mathcal{F}) \xrightarrow{j_*} H^1(M, \mathcal{F}/\mathcal{F}^{(0)}) \xrightarrow{\delta_*} \dots \end{aligned} \quad (32)$$

Taking into account the isomorphism of cohomologies on differentiable manifolds, cohomologies $H^*(M, \mathcal{F}^{(0)})$, $H^*(M, \mathcal{F})$, $H^*(M, \mathcal{F}/\mathcal{F}^{(0)})$ can be identified with de Rham cohomologies with coefficients in a sheaf [30]. Additional degrees of freedom are determined by cohomologies $H^*(M, \mathcal{F}/\mathcal{F}^{(0)})$ in the sequence (32). If cohomologies $H^*(M, \mathcal{F}/\mathcal{F}^{(0)})$ on the manifold M are nontrivial, fields $p_j(\vec{r}, \tau)$ in equation (10) are changed by fields $p_{j,J}(\vec{r}, \tau)$, where J is the multi-index given by cohomology classes corresponding to group elements of $H^*(M, \mathcal{F}/\mathcal{F}^{(0)})$. This leads to the existence of additional excitations.

If the quantum system is determined on a Riemann surface, then we can take the sheaf of meromorphic functions \mathcal{M}^* distinct from zero on the manifold M and the subsheaf of nonzero holomorphic functions \mathcal{O}^* as sheaves \mathcal{F} and $\mathcal{F}^{(0)}$, respectively. Then, additional degrees of freedom are given by the divisor group $\text{Div}(M) = H^0(M, \mathcal{M}^*/\mathcal{O}^*)$ [29, 31] and correspond to vortex excitations.

5. Simplification of diagram expansions for special cases

5.1. Heisenberg algebra (superalgebra)

Heisenberg algebra (superalgebra) possesses the set of generators $\{I, a(\vec{1}), a^+(\vec{1}), \varepsilon(\vec{1}) = a^+(\vec{1})a(\vec{1})\}$ with nonzero commutation relations

$$\begin{aligned} [a(\vec{1}), a^+(\vec{1})] &= I \\ [\varepsilon(\vec{1}), a(\vec{1})] &= -a(\vec{1}) \\ [\varepsilon(\vec{1}), a^+(\vec{1})] &= a^+(\vec{1}). \end{aligned} \quad (33)$$

Other commutation relations are trivial. a^+ , a and I are creation, annihilation and identical operators, respectively. Cartan's subalgebra H is spanned on vectors $I, \varepsilon(\vec{1})$: $H = \text{Span}\{I, \varepsilon(\vec{1})\}$. The Hamiltonian (1) describes interacting Bose and Fermi systems and has the form

$$\begin{aligned} \mathcal{H} = \sum_{\vec{1}} [(p_I + N(\vec{1}))I + (p_\varepsilon + E(\vec{1}))\varepsilon(\vec{1}) + p_- a(\vec{1}) + p_+ a^+(\vec{1})] \\ + \sum_{\substack{\vec{1}, \vec{1}' \\ (\vec{1} \neq \vec{1}')}} V(\vec{1} - \vec{1}') \varepsilon(\vec{1}) \varepsilon(\vec{1}'), \end{aligned} \quad (34)$$

where $N(\vec{1})$ and $E(\vec{1})$ are the external fields corresponding to operators I and $\varepsilon(\vec{1})$, respectively. Equation (13) for the functional $W[p]$ are determined by commutation relations (33) and the Hamiltonian (34) and are written in the form

$$\begin{aligned} \left[\frac{\partial}{\partial \tau} \pm (p_\varepsilon(\vec{1}, \tau) + E(\vec{1})) \right] \frac{\delta W[p]}{\delta p_\mp(\vec{1}, \tau)} = \mp p_\pm(\vec{1}, \tau) \frac{\delta W[p]}{\delta p_I(\vec{1}, \tau)}, \\ \frac{\partial}{\partial \tau} \frac{\delta W[p]}{\delta p_\varepsilon(\vec{1}, \tau)} = p_-(\vec{1}, \tau) \frac{\delta W[p]}{\delta p_-(\vec{1}, \tau)} - p_+(\vec{1}, \tau) \frac{\delta W[p]}{\delta p_+(\vec{1}, \tau)}, \\ \frac{\partial}{\partial \tau} \frac{\delta W[p]}{\delta p_I(\vec{1}, \tau)} = 0. \end{aligned} \quad (35)$$

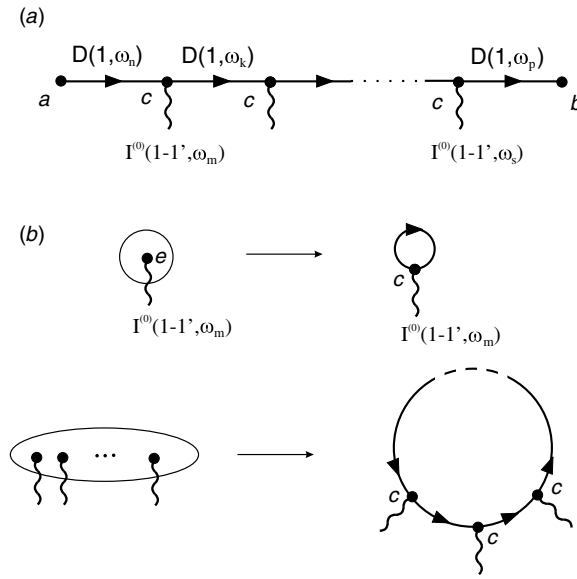

Figure 2. (a) Propagators tied by c -vertices with external a - and b -vertices. (b) Blocks with isolated e -vertices and transformation from blocks to propagator loops.

Root spaces $\mathcal{L}_a, \mathcal{L}_{a^+}$ are one-dimensional, therefore, f -vertices are absent in the diagram expansion. In the analyzing model only one propagator (24) exists:

$\delta^2 W[p] / \delta p_-(\vec{1}, \tau) \delta p_+(\vec{1}, \tau) |_{p \rightarrow 0} = D(\vec{1}, \tau - \tau')$. In the frequency representation (28), the propagator is given by

$$D(\vec{1}, \omega_n) = \frac{1 - (-1)^{n+1} \kappa_{aa}}{2[i\omega_n - E(\vec{1})]}, \tag{36}$$

where $\kappa_{aa} = 1$ for Bose systems and $\kappa_{aa} = -1$ for Fermi ones. Taking into account that the root of the propagator is α_{a^+} with $\alpha_{a^+}(I) = 0$ and the form of the interaction is given by the Hamiltonian (34), from the law of conservation of roots in a vertex we deduce that d -vertices are absent in the diagram expansion.

Let us consider a block containing propagators (36). From the first equation (35), it follows that the block with one isolated part corresponds to the differentiation $\delta W[p] / \delta p_I(\vec{1}, \tau)$. From the third equation (35), we can conclude that derivatives of $W[p]$ with respect to $p_I(\vec{1}, \tau)$ of higher orders are equal to zero. Consequently, if the block contains propagators, then this block has only one connected part. In this case, the block designation can be dropped out in diagrams. Thus, for the model with the Hamiltonian (34) diagrams contain the following.

- (a) Propagators without block designations. Propagators are tied by c -vertices with $v_c(a^+; a^+ | \varepsilon) = 1$. The a - and b -vertices are external with $v_a(-; a^+ | a^+) = v_b(a^+; I | a) = 1$ (figure 2(a)).
- (b) Blocks with n isolated e -vertices corresponding to derivatives $\delta^n W / \delta p_\varepsilon \cdots \delta p_\varepsilon |_{p \rightarrow 0}$ (figure 2(b)).

Blocks with isolated e -vertices can be transformed by substitution of propagator loops for blocks. The transformation is based on the relation $\varepsilon(\vec{1}) = a^+(\vec{1})a(\vec{1})$. Due to this relation, in derivatives $\delta^n W / \delta p_\varepsilon \cdots \delta p_\varepsilon |_{p \rightarrow 0}$ the differentiation $\delta / \delta p_\varepsilon(\vec{1}, \tau)$ can be substituted by the

differentiation $\delta^2/\delta p_{\alpha^+}(\vec{1}, \tau)\delta p_{\alpha}(\vec{1}, \tau)$. This corresponds to propagator loops with c -vertices in diagrams. If a diagram contains m propagator loops, then its analytical expression must be multiplied by the coefficient κ_{aa}^m . After this transformation, the diagram expansion takes on the form of well-known Feynman's diagrams.

5.2. Semi-simple Lie algebras and simple contragredient Lie superalgebras

Similarly to the above-mentioned case of the Heisenberg algebra, for semi-simple algebras diagram expansions can be simplified. Root spaces \mathcal{L}_{α} are one-dimensional. This leads to the absence of f -vertices. Due to the non-degeneration of the Killing form on \mathcal{L} , each root α corresponds to the root vector $h_{\alpha} \in H$ according to the relation [26, 27]

$$\alpha(\sigma^{(H)}) = (h_{\alpha}, \sigma^{(H)}), \quad (37)$$

where (\dots, \dots) is the Killing form. Vectors h_{α} are expressed in terms of normalized operators $\sigma^{(\alpha)}, \sigma^{(-\alpha)}$. The operator normalization is chosen so that $(\sigma^{(\alpha)}, \sigma^{(-\alpha)}) = 1$. Then, vectors h_{α} can be written as [26, 27]

$$h_{\alpha} = [\sigma^{(\alpha)}, \sigma^{(-\alpha)}].$$

Cartan's subalgebra H is completely determined by the vectors h_{α} . The Killing form is positive definite on Cartan's subalgebra and induces the Euclidean geometry on H . Taking into account the one-to-one correspondence between roots α and root vectors h_{α} , we can write the law of conservation of roots (25) in the form

$$h_{\alpha_i}^{(\text{field})} + \sum_j h_{\alpha_j}^{(\text{in})} - h_{\alpha_i}^{(\text{out})} = 0.$$

For the case of Lie algebras of high dimensions, this representation of the law of conservation of roots can be more efficient in comparison with relation (25), because we can use Euclidean properties of the subalgebra H .

The special cases of simple contragredient Lie superalgebras are $A(m, n), B(m, n), C(n), D(m, n), D(2, 1; \alpha), F(4), G(3)$ [28]. For these superalgebras root spaces \mathcal{L}_{α} are one-dimensional. The superalgebras possess supersymmetric bilinear non-degenerate forms, which are invariant under automorphisms of superalgebras and can be different from the Killing form. The existence of these forms allows us to make transformation to root vectors h_{α} in accordance with relation (37). The above-mentioned properties lead to simplifications of diagram expansions, analogous to simplifications for semi-simple Lie algebras. In particular, these simplifications can be used for the superalgebra $A(1, 1)$ (or, in other definition, $sl(2, 2)$), which corresponds to the Hubbard model [10–14].

6. Self-consistent-field approximation and introduction of the matrix of effective Green functions and interactions

6.1. Self-consistent field

The self-consistent-field approximation is equivalent to a rearrangement of the terms in the Hamiltonian \mathcal{H}_0 in relation (2). The terms with the interaction V_{ij} are added to the fields $b_j(\vec{1})$

$$\mathcal{H}_b \rightarrow \mathcal{H}_b^{(s)} = \sum_{\vec{1}, j} b_j(\vec{1})\sigma_j(\vec{1}) + \sum_{\substack{\vec{1}, \vec{1}' \\ i, j}} V_{ij}(\vec{1} - \vec{1}')\langle\langle\sigma_i(\vec{1})\rangle\rangle_0\sigma_j(\vec{1}') = \sum_{\vec{1}, j} B_j(\vec{1})\sigma_j(\vec{1}), \quad (38)$$

where $B_j(\vec{1}) = b_j(\vec{1}) + \sum_{i, \vec{1}'} V_{ij}(\vec{1}' - \vec{1})\langle\langle\sigma_i(\vec{1}')\rangle\rangle_0$. In the framework of the diagram technique given by relations (27) and (30), the rearrangement in the Hamiltonian \mathcal{H}_0 corresponds

to the summation of all diagrams that can be divided into two parts through breaking an interaction line. One of the parts does not have external vertices (so-called one-tail part of the diagrams). Since in the self-consistent-field approximation the quantum system is in the thermodynamic equilibrium, then the set of observable variables consists of r commuting operators $\sigma_j(\vec{1})$ with $\langle\langle\sigma_j(\vec{1})\rangle\rangle_0 \neq 0$. In the common case, the set of commuting operators gives new Cartan's subalgebra, which is conjugated to the previous Cartan's subalgebra, where the self-consistent-field approximation is not taken into account. After transformation to new Cartan's subalgebra the diagram expansion is given by relations (27) and (30), where the substitution $b_j(\vec{1}) \rightarrow B_j(\vec{1})$ is performed.

6.2. Matrix of effective Green functions and interactions: quasi-particle excitations

In order to describe quasi-particle excitations, we introduce the matrix of effective Green functions and interactions (the \mathcal{P} -matrix) in the frequency representation,

$\mathcal{P} = \|P_{JN}(\vec{1}, \vec{1}', \omega_m)\|$ [32]. We compose the \mathcal{P} -matrix from analytical expressions of connected diagrams with two external sites. These sites are end points of propagators, single vertices e , or end points of interaction lines. Accordingly, multi-indices $J = (wj)$, $N = (wn)$ are the double indices, where j, n correspond to indices of fields p_j, p_n in derivatives of the functional Z of the second order in relation (11) or indices of interaction lines. The index w points out that J, N belong to a propagator or to a e -vertex ($w = 1$), or belong to an interaction line ($w = 2$). The zero-order approximation $\mathcal{P}^{(0)}$ of the \mathcal{P} -matrix is determined by the matrix of the bare interaction $\mathcal{I}^{(0)} = \|I_{jn}^{(0)}(\vec{1} - \vec{1}', \omega_m)\|$, given by relation (29), and by the bare two-site Green functions in the self-consistent-field approximation $\mathcal{G}^{(0)} = \|G_{jn}^{(0)}(\vec{1}, \vec{1}', \omega_m)\| = \|\delta^2 W / \delta p_j \delta p_n\|$ (figure 3(a)), given on a crystal lattice site

$$\mathcal{P}^{(0)} = \begin{pmatrix} \|P_{(1j)(1n)}^{(0)}\| & \|P_{(1j)(2n)}^{(0)}\| \\ \|P_{(2j)(1n)}^{(0)}\| & \|P_{(2j)(2n)}^{(0)}\| \end{pmatrix} = \begin{pmatrix} \|G_{jn}^{(0)}\| & 0 \\ 0 & \|I_{jn}^{(0)}\| \end{pmatrix}. \quad (39)$$

If the indices j, n correspond to non-Cartan's fields, then in accordance with relations (28) and (30), the bare Green functions are expressed in terms of b -vertex factors, propagators and block factors:

$$G_{jn}^{(0)}(\vec{1}, \vec{1}', \omega_m) = \sum_k v_b(n; k|j) D_n(\vec{1}, \omega_m) \Gamma_k^{(H)}(\vec{1}) \delta_{\vec{1}\vec{1}'}, \quad (40)$$

where the propagator $D_n(\vec{1}, \omega_m)$ is given by relation (28) with $f_n(\vec{1}) = \sum_{l=1}^r \alpha_n(\sigma_l^{(H)}) B_l(\vec{1})$. For indices j, n of the Cartan type, the bare Green functions are determined by block factors (23): $G_{jn}^{(0)}(\vec{1}, \vec{1}', \omega_m) = \Gamma_{jn}^{(H)}(\vec{1}) \delta_{\vec{1}\vec{1}'} \delta_{m0}$. If one of the indices j, n belongs to the Cartan type and another index is of the non-Cartan type, then the Green functions $G_{jn}^{(0)}$ are equal to zero.

The next approximation of the \mathcal{P} -matrix, $\mathcal{P}^{(1)}$, is obtained by means of the summation of the $\mathcal{P}^{(0)}$ -matrix (39)—the summation of all diagram chains consisting of bare Green functions $G_{jn}^{(0)}$ and the bare interaction lines $I_{jn}^{(0)}$ (figures 3(b)–(d)). These chains of propagators and interaction lines do not have any loop insertion. Analytical expressions of the considered diagrams can be written in accordance with relation (30). The summation gives an equation of the Dyson type

$$\begin{aligned} \mathcal{P}^{(1)} &= \|P_{JN}^{(0)}(\vec{1}, \vec{1}', \omega_m)\| + \sum_{\vec{2}, K, L} \|P_{JK}^{(1)}(\vec{1}, \vec{2}, \omega_m)\| \cdot \|\Xi_{KL}\| \cdot \|P_{LN}^{(0)}(\vec{2}, \vec{1}', \omega_m)\| \\ &= \mathcal{P}^{(0)} + \mathcal{P}^{(1)} \Xi \mathcal{P}^{(0)}, \end{aligned} \quad (41)$$

(a) $G_{jn}^{(0)} = \begin{array}{|c|} \hline \text{---} \text{---} \text{---} \\ \hline \end{array} = \left\{ \begin{array}{l} \text{---} \text{---} \text{---} \\ \text{---} \text{---} \text{---} \\ \text{---} \text{---} \text{---} \end{array} \right.$

(b) $P_{(1j)(1n)}^{(1)} = G_{jn}^{(1)} = \begin{array}{|c|} \hline \text{---} \text{---} \text{---} \\ \hline \end{array} = \begin{array}{|c|} \hline \text{---} \text{---} \text{---} \\ \hline \end{array} + \sum_{\gamma_1 \gamma_2} \begin{array}{|c|} \hline \text{---} \text{---} \text{---} \\ \hline \end{array} + \sum_{\gamma_1 \dots \gamma_4} \begin{array}{|c|} \hline \text{---} \text{---} \text{---} \\ \hline \end{array} + \dots + \sum_f \begin{array}{|c|} \hline \text{---} \text{---} \text{---} \\ \hline \end{array} + \dots =$

$= \begin{array}{|c|} \hline \text{---} \text{---} \text{---} \\ \hline \end{array} + \sum_{\gamma_1 \gamma_2} \begin{array}{|c|} \hline \text{---} \text{---} \text{---} \\ \hline \end{array} + \sum_f \begin{array}{|c|} \hline \text{---} \text{---} \text{---} \\ \hline \end{array}$

(c) $P_{(2j)(2n)}^{(1)} = I_{jn}^{(1)} = \begin{array}{|c|} \hline \text{---} \text{---} \text{---} \\ \hline \end{array} = \begin{array}{|c|} \hline \text{---} \text{---} \text{---} \\ \hline \end{array} + \sum_{\gamma_1 \gamma_2 f} \begin{array}{|c|} \hline \text{---} \text{---} \text{---} \\ \hline \end{array}$

(d) $P_{(1j)(2n)}^{(1)} = \begin{array}{|c|} \hline \text{---} \text{---} \text{---} \\ \hline \end{array} = \sum_{\gamma} \begin{array}{|c|} \hline \text{---} \text{---} \text{---} \\ \hline \end{array}$

$P_{(2j)(1n)}^{(1)} = \begin{array}{|c|} \hline \text{---} \text{---} \text{---} \\ \hline \end{array} = \sum_{\gamma} \begin{array}{|c|} \hline \text{---} \text{---} \text{---} \\ \hline \end{array}$

Figure 3. (a) Definition of bare two-site Green functions $G_{jn}^{(0)}$. (b) Definition of effective Green functions $P_{(1j)(1n)}^{(1)} = G_{jn}^{(1)}$ via the bare Green functions $G_{jn}^{(0)}$. (c) Definition of effective interaction lines $P_{(2j)(2n)}^{(1)} = I_{jn}^{(1)}$. (d) Definition of intersecting terms $P_{(1j)(2n)}^{(1)}, P_{(2j)(1n)}^{(1)}$. Summation over γ and f denotes the summation over indices of propagators, interaction lines and vertices, space variables and indices of f -vertices, respectively.

where

$$\Xi = \begin{pmatrix} 0 & \mathcal{E} \\ \mathcal{E} & 0 \end{pmatrix}, \quad \mathcal{E} = \|\delta_{jn}\| \text{ is the diagonal matrix.}$$

Taking into account $\mathcal{E} - \mathcal{G}^{(0)}\mathcal{I}^{(0)} = \mathcal{G}^{(0)}(\mathcal{E} - \mathcal{I}^{(0)}\mathcal{G}^{(0)})\mathcal{G}^{(0)-1}$, we find that the solution of equation (41) is the matrix

$$\mathcal{P}^{(1)} = \mathcal{P}^{(0)}(1 - \Xi\mathcal{P}^{(0)})^{-1} = \begin{pmatrix} \mathcal{G}^{(0)}(\mathcal{E} - \mathcal{I}^{(0)}\mathcal{G}^{(0)})^{-1} & (\mathcal{E} - \mathcal{G}^{(0)}\mathcal{I}^{(0)})^{-1}\mathcal{G}^{(0)}\mathcal{I}^{(0)} \\ \mathcal{I}^{(0)}\mathcal{G}^{(0)}(\mathcal{E} - \mathcal{I}^{(0)}\mathcal{G}^{(0)})^{-1} & \mathcal{I}^{(0)}(\mathcal{E} - \mathcal{G}^{(0)}\mathcal{I}^{(0)})^{-1} \end{pmatrix}. \quad (42)$$

The $\mathcal{P}^{(1)}$ -matrix consists of effective Green functions $\mathcal{G}^{(1)} = \|\mathcal{G}_{jn}^{(1)}\| = \|P_{(1j)(1n)}^{(1)}\| = \mathcal{G}^{(0)}(\mathcal{E} - \mathcal{I}^{(0)}\mathcal{G}^{(0)})^{-1}$, effective interactions $\mathcal{I}^{(1)} = \|I_{jn}^{(1)}\| = \|P_{(2j)(2n)}^{(1)}\| = \mathcal{I}^{(0)}(\mathcal{E} - \mathcal{G}^{(0)}\mathcal{I}^{(0)})^{-1}$

and intersecting terms $P_{(1j)(2n)}^{(1)}, P_{(2j)(1n)}^{(1)}$. Effective Green functions, effective interactions and intersecting terms are denoted in diagrams by directed thick lines, empty lines and compositions of the thick line–empty line, respectively. Approximations of the \mathcal{P} -matrix of higher orders, s , are determined by summation of diagrams consisting of s loops.

Introduction of the \mathcal{P} -matrix leads to the desire to use it in diagram expansions with effective Green functions and interactions. Substitution of effective Green functions and interactions for the bare ones can be completely performed only for models with the Heisenberg algebra (superalgebra). As a result of the substitution, we obtain Feynman's diagrams with effective propagators and interaction lines. For models with arbitrary Lie algebras \mathcal{L} the complete substitution is not held. This obstruction is caused by transformation of block structures of diagrams. The block transformation results in compensating diagrams, in which partial substitutions of effective Green functions and interaction lines for the bare ones have been performed.

Spectrum relations of quasi-particle excitations are given by the \mathcal{P} -matrix poles—by zero eigenvalues of the operator $1 - \Xi\mathcal{P}^{(0)}$ or, equivalently, by $\mathcal{E} - \mathcal{I}^{(0)}\mathcal{G}^{(0)}$ under the analytical continuation (31). Since, zero eigenvalues of these operators can be corresponded to different eigenfunctions and can determine different excitation modes, we introduce the spectral parameter λ for eigenfunctions $p_j^{(\lambda)}(\vec{1}, \omega_m)$. The spectral parameter λ can be discrete or continuous. Taking into account the above-mentioned, we get the equation describing quasi-particle excitations

$$p_j^{(\lambda)}(\vec{1}, \omega_m) - \sum_{\vec{1}', k, i} I_{jk}^{(0)}(\vec{1} - \vec{1}', \omega_m) G_{ki}^{(0)}(\vec{1}', \vec{1}', \omega_m) p_i^{(\lambda)}(\vec{1}', \omega_m) \Big|_{i\omega_m \rightarrow \omega + i\epsilon \operatorname{sign}\omega} = 0. \quad (43)$$

7. Spin system model with an uniaxial anisotropy

As the case of application of the developed diagram technique, we consider a model of a spin ensemble with an uniaxial anisotropy.

$$\begin{aligned} \mathcal{H}_0 = & -g\mu_B \sum_{\vec{1}} [S^z(\vec{1})H_z(\vec{1}) + (S^z)^2(\vec{1})H_a(\vec{1})] \\ & - \frac{1}{2} \sum_{\vec{1}, \vec{1}'} J(\vec{1} - \vec{1}') [S^z(\vec{1})S^z(\vec{1}') + S^-(\vec{1})S^+(\vec{1}')], \end{aligned} \quad (44)$$

where $H_z(\vec{1})$ is the external magnetic field and $H_a(\vec{1})$ is the anisotropy field. We assume that the absolute value of spins is 1, $|S| = 1$. g and μ_B are the Lande factor and the Bohr magneton, respectively.

Let us perform transformation from the Lie algebra $\mathcal{L}^{(0)} = \{S^+, S^-, S^z\}$ to the Lie algebra $\mathcal{L}^{(1)}$ generated by the composite operators $S^\mu S^\nu$. This transformation allows us to take into account the anisotropy in the zero-order approximation. The algebra $\mathcal{L}^{(1)}$ is isomorphic to the algebra $gl(3)$ of 3×3 matrices and describes the quadrupole spin dynamics [33, 34]. The operator $(S^z)^2$ is contained in the algebra $\mathcal{L}^{(1)}$ and the algebra $\mathcal{L}^{(0)}$ is the subalgebra of $\mathcal{L}^{(1)}$: $\mathcal{L}^{(0)} \subset \mathcal{L}^{(1)}$. Matrices

$$E_{ij} = i \begin{pmatrix} & & j \\ 0 & \vdots & 0 \\ \cdots & 1 & \cdots \\ 0 & \vdots & 0 \end{pmatrix}$$

form the basis of the algebra $gl(3)$. Spin operators, by whose the Hamiltonian \mathcal{H}_0 (44) is written, are expressed via the matrices E_{ij}

$$\begin{aligned} S^z &= E_{11} - E_{33}, \\ S^{z^2} &= E_{11} + E_{33}, \\ S^+ &= E_{12} + E_{23}, \\ S^- &= E_{21} + E_{32}. \end{aligned}$$

The algebra $\mathcal{L}^{(1)} = gl(3)$ can be decomposed with the direct sum $\mathcal{L}^{(1)} = \text{Span}\{I\} \oplus sl(3)$, where $sl(3)$ is the semi-simple Lie algebra isomorphic to the algebra of matrices with zero traces and I is the identical operator. The Cartan subalgebra H of the algebra $gl(3)$ can be chosen as the subalgebra spanned on diagonal operators $h^{(1)} = \|h_{ij}^{(1)}\| = E_{11} - E_{33}$, $h^{(2)} = \|h_{ij}^{(2)}\| = E_{11} - E_{22}$ and $h^{(3)} = \|h_{ij}^{(3)}\| = E_{11} + E_{22} + E_{33}$. The operator $(S^z)^2$ is expressed via operators $h^{(k)}$, $(S^z)^2 = -h^{(1)}/3 + 2h^{(2)}/3 + 2h^{(3)}/3$. Roots α_{ij} of the Lie algebra $gl(3)$ are linear forms satisfying the condition $\alpha_{ij}(h^{(k)}) = h_{ii}^{(k)} - h_{jj}^{(k)}$. The root space corresponding to the form α_{ij} is the one-dimensional space $E_{\alpha_{ij}} = cE_{ij}$ ($c \in \mathbb{C}$). In order to define propagators (28), we choose roots $\alpha_{12}, \alpha_{32}, \alpha_{13}$. Then, in the frequency representation, three roots α_{jk} determine three propagators

$$D_{(jk)}(\vec{1}, \omega_n) = \frac{1}{i\omega_n - f_{jk}(\vec{1})}, \quad (45)$$

where $\omega_n = 2\pi n$; $f_{jk}(\vec{1}) = \sum_{l=1}^3 \alpha_{jk}(h^{(l)})b_l(\vec{1})$; (jk) is the double index equal 12, 32 and 13; $b_1(\vec{1}) = -g\mu_B[H_z(\vec{1}) - H_a(\vec{1})]/3$, $b_2(\vec{1}) = -2g\mu_B H_a(\vec{1})/3$, $b_3(\vec{1}) = -2g\mu_B H_a(\vec{1})/3$ are external fields in the Hamiltonian (2) corresponding to the operators $h^{(1)}, h^{(2)}, h^{(3)}$ of Cartan's subalgebra, respectively. Taking into account the explicit form of the fields $b_l(\vec{1})$ and the scale transformation $-\beta b_l \rightarrow b_l$ performed in section 2, we can write the energies $f_{jk}(\vec{1})$ in relation (45) as

$$\begin{aligned} f_{12}(\vec{1}) &= \beta g\mu_B [H_z(\vec{1}) + H_a(\vec{1})], \\ f_{32}(\vec{1}) &= \beta g\mu_B [-H_z(\vec{1}) + H_a(\vec{1})], \\ f_{13}(\vec{1}) &= 2\beta g\mu_B H_z(\vec{1}). \end{aligned} \quad (46)$$

The functional $W[p^{(H)}]$ (22) can be written in the form

$$\begin{aligned} W[p^{(H)}] &= \sum_{\vec{1}} \ln[\exp(u_1(\vec{1}) + u_2(\vec{1}) + u_3(\vec{1})) \\ &\quad + \exp(-u_2(\vec{1}) + u_3(\vec{1})) + \exp(-u_1(\vec{1}) + u_3(\vec{1}))], \end{aligned} \quad (47)$$

where $u_j(\vec{1}) = -\beta[b_j(\vec{1}) + p_j^{(H)}(\vec{1})]$, $p_j^{(H)}(\vec{1})$ are infinitesimal auxiliary fields. In the self-consistent-field approximation (38), the magnetic field $H_z(\vec{1})$ is rearranged

$$H_z^{(s)}(\vec{1}) = H_z(\vec{1}) + \sum_{\vec{1}'} J(\vec{1} - \vec{1}') \langle\langle S^z(\vec{1}') \rangle\rangle_0.$$

The transformation $H_z(\vec{1}) \rightarrow H_z^{(s)}(\vec{1})$ results in changes in the external field $b_1(\vec{1})$ and in the energies $f_{jk}(\vec{1})$ in relation (46). In the self-consistent-field approximation, the nonzero bare Green functions (40) with indices (jk) corresponding to nondiagonal operators E_{jk} have the form

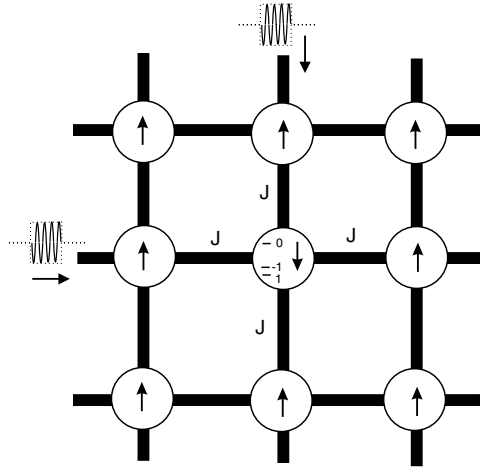

Figure 4. Spin memory cells with spin anisotropy. J is the interaction between cells.

$$\begin{aligned}
 G_{(12)(21)}^{(0)}(\vec{1}, \omega_n) &= \frac{-1}{\beta[i\omega_n - f_{12}(\vec{1})]} \cdot \frac{\partial W}{\partial b_2(\vec{1})}, \\
 G_{(32)(23)}^{(0)}(\vec{1}, \omega_n) &= \frac{-1}{\beta[i\omega_n - f_{32}(\vec{1})]} \cdot \left[\frac{\partial W}{\partial b_1(\vec{1})} - \frac{\partial W}{\partial b_2(\vec{1})} \right], \\
 G_{(13)(31)}^{(0)}(\vec{1}, \omega_n) &= \frac{-1}{\beta[i\omega_n - f_{13}(\vec{1})]} \cdot \frac{\partial W}{\partial b_1(\vec{1})}.
 \end{aligned} \tag{48}$$

The bare Green functions with indices corresponding to diagonal operators $h^{(k)}$ ($k = 1, 2, 3$) are functions $G_{(ii)(jj)}^{(0)}(\vec{1}, \omega_n) = [\delta^2 W / \delta b_i(\vec{1}) \delta b_j(\vec{1})] \cdot \delta_{n0}$. For indices $i, j = 1, 2$, Green's functions $G_{(ii)(jj)}^{(0)}$ differ from zero. If one of the indices i or j is equal to 3, then $G_{(ii)(jj)}^{(0)} = 0$. Bare Green's functions $G_{(ij)(kn)}^{(0)}$ and the bare interaction $J(\vec{1} - \vec{1}')$ determine the matrix of effective Green's functions and interactions $\mathcal{P}^{(1)}$ (42). Dispersion relations of quasi-particle excitations (43) are given by the $\mathcal{P}^{(1)}$ -matrix poles. Taking into account relations (46)–(48), we can conclude that the given spin model possesses three modes of spin waves corresponding to transitions between energy levels of non-equidistant spectrum. Transitions between levels are induced by nondiagonal operators E_{ij} . The non-equidistance of the spectrum is due to the anisotropy field H_a . Initial points of spin wave dispersion curves are determined by differences of energies of non-equidistant spectrum levels and correspond to energies f_{12}, f_{32}, f_{13} .

The spin model (44) is important for applications as the model describing spin memory cells (figure 4). For $H_a > H_z$, two states with energy minima exist in a cell, $|1\rangle$ with $S_z = 1$ and $|-1\rangle$ with $S_z = -1$. Due to high values of the field H_a , transitions between these states, $|1\rangle \rightarrow |0\rangle \rightarrow |-1\rangle$ and $|-1\rangle \rightarrow |0\rangle \rightarrow |1\rangle$, are realized by jumping over the state $|0\rangle$ ($S_z = 0$) with the energy maximum. This makes possible to write one bit of information. Transitions can be induced by pulses of alternating current flowing in vertical and horizontal transfer buses. Pulse duration must be sufficient to change the magnetization of the cell, where buses are crossed, and is insufficient to remagnetize other cells. Reading can be performed by means of alternating current of lesser frequency corresponding to the difference of energies of states $|1\rangle$ and $|-1\rangle$ and proportional to the energy $f_{13} = 2H_z$. Mutual influence of information bits written in neighboring cells is determined by spin wave excitation given by equation (43).

8. Conclusion

The results of the investigations performed can be summarized as follows.

- (1) We construct diagram expansions for models with internal Lie-group dynamics. Internal Lie groups are related to finite-dimensional Lie algebras and Lie superalgebras. The diagram technique is based on the expansion of the generating functional for the temperature Green functions, which is determined by differential functional equations. Solutions of the differential functional equations are found in the form of series. This method of the construction of the diagram expansion is more general than the methods based on the Wick theorem and on the expansion of functional integrals. The advantage of the developing diagram technique is the opportunity to construct effective cluster approximations for models with strong local interactions. It can be realizable by substitution of composite operators for single-particle operators in the Hamiltonian describing a model. This operator substitution leads to the substitution of Lie algebras. The original Lie algebra $\mathcal{L}^{(0)}$ describing the internal dynamics of the quantum system is replaced by the Lie algebra $\mathcal{L}^{(1)}$, which includes $\mathcal{L}^{(0)}$ as the subalgebra: $\mathcal{L}^{(0)} \subset \mathcal{L}^{(1)}$. The example of this substitution is the change of Fermi creation–annihilation operators by Hubbard operators in the Hubbard model with the strong Coulomb interaction on crystal lattice sites.
- (2) The differential representation makes us possible to generalize functional equations and the diagram technique for the case of quantum systems on topologically nontrivial manifolds by the substitution of the generating functional on a sheaf of function rings on a nontrivial manifold for the generating functional of a constant sheaf of functions. Nontrivial cohomologies of the manifold, on which the quantum system is acted, lead to the existence of additional excitations.
- (3) The simplification of the diagram technique occurs for models with semi-simple Lie algebras and with simple contragredient Lie superalgebras. For the case of the Heisenberg algebra (superalgebra), the diagram expansion reduces to Feynman’s diagrams for Bose (Fermi) quantum systems.
- (4) In order to find quasi-particle excitations, we introduce the \mathcal{P} -matrix—the matrix of effective Green functions and interactions. The \mathcal{P} -matrix is obtained by summation of series of the bare interaction $\mathcal{I}^{(0)}$ and the bare Green functions $\mathcal{G}^{(0)}$. Dispersion relations of quasi-particle excitations are given by the \mathcal{P} -matrix poles—by zero eigenvalues of the operator $\mathcal{E} - \mathcal{I}^{(0)}\mathcal{G}^{(0)}$, where \mathcal{E} is the unity operator.
- (5) We consider the reduction of the developed diagram technique and excitations for the case of the spin system with an uniaxial anisotropy. This model is important for applications as the model describing spin memory cells.

Acknowledgment

This work was supported by the Russian Foundation for Basic Research, grant no 06-02-17030.

References

- [1] Nalwa H S (ed) 2004 *Encyclopedia of Nanoscience and Nanotechnology* (CA: American Scientific Publishers)
- [2] Rieth M and Schommers W (eds) 2006 *Atomistic Simulations—Algorithms and Methods* vol 2, *Quantum and Molecular Computing, and Quantum Simulations* vol 3 *Handbook of Theoretical and Computational Nanotechnology* (CA: American Scientific Publishers)

- [3] Abrikosov A A, Gor'kov L P and Dzyaloshinski I E 1975 *Methods of Quantum Field Theory in Statistical Physics* (New York: Dover)
- [4] Lifshitz E M and Pitaevskii L P 1991 *Statistical Physics Part 2* (Oxford: Pergamon)
- [5] Mancini F and Avella A 2004 *Adv. Phys.* **53** 537
- [6] Demler E, Hanke W and Zhang S-C 2004 *Rev. Mod. Phys.* **76** 909
- [7] Izyumov Yu A, Kassan-ogly F A and Skryabin Yu N 1974 *Field Methods in the Theory of Ferromagnetism* (Moscow: Nauka)
- [8] Vaks V G, Larkin A I and Pikin S A 1967 *Sov. Phys.—JETP* **26** 188
- [9] Vaks V G, Larkin A I and Pikin S A 1967 *Sov. Phys.—JETP* **26** 647
- [10] Hubbard J 1963 *Proc. R. Soc. A* **276** 238
- [11] Hubbard J 1964 *Proc. R. Soc. A* **277** 237
- [12] Izyumov Yu A and Skryabin Yu N 1988 *Statistical Mechanics of Magnetically Ordered Systems* (New York: Consultants Bureau)
- [13] Zaitsev R O 1976 *Sov. Phys.—JETP* **43** 574
- [14] Zaitsev R O 1978 *Sov. Phys.—JETP* **48** 1193
- [15] Westwanski B 1973 *Phys. Lett. A* **44** 27
- [16] Maier T, Jarrell M, Pruschke T and Hettler M H 2005 *Rev. Mod. Phys.* **77** 1027
- [17] Kakehashi Y 2004 *Adv. Phys.* **53** 497
- [18] Batista C D and Ortiz G 2004 *Adv. Phys.* **53** 1
- [19] Vinogradov A M, Krasil'shchik J S and Lychagin V V 1986 *Introduction to Geometry of Nonlinear Differential Equations* (Moscow: Nauka)
- [20] Vinogradov A 2001 *Cohomological Analysis of Partial Differential Equations and Secondary Calculus (Translations of Mathematical Monographs vol 204)* (Providence, RI: American Mathematical Society)
- [21] Krasil'shchik J and Verbovetsky A 1998 Homological methods in equations of mathematical physics *Preprint DIPS-7/98*, <http://diffiety.ac.ru>
- [22] Steenrod N E and Epstein D B A 1962 *Cohomology Operations* (Princeton, NJ: Princeton University Press)
- [23] Vasil'ev A N 1997 *Functional Methods in Quantum Field Theory and Statistical Physics* (London: Taylor and Francis)
- [24] Nazaikinskii V E, Shatalov V E and Sternin B Yu 1996 *Methods of Noncommutative Analysis* (Berlin: Walter de Gruyter)
- [25] Dixmier J 1974 *Algebres enveloppantes* (Paris: Gauthier-Villars)
- [26] Goto M and Grosshans F 1978 *Semisimple Lie Algebres (Lecture Notes in Pure and Applied Mathematics vol 38)* (New York: Dekker)
- [27] Jacobson N 1962 *Lie Algebres* (New York: Wiley-Interscience)
- [28] Kac V G 1977 *Adv. Math.* **26** 8
- [29] Griffiths P and Harris J 1978 *Principles of Algebraic Geometry* (New York: Wiley)
- [30] Warner F W 1983 *Foundations of Differentiable Manifolds and Lie Groups* (New York: Springer)
- [31] Springer G 1981 *Introduction to Riemann Surfaces* (New York: Chelsea)
- [32] Lutsev L V 2005 *J. Phys.: Condens. Matter* **17** 6057
- [33] Corio R L 1968 *J. Math. Phys.* **9** 1067
- [34] Kopvillem U Kh and Prants S V 1977 *Phys. Status Solidi b* **83** 109